

KOLOSSAL 330 IK US SA Semi-Automatic Slicer

Key Features

- » Gear Drive System
- » Built-In Sharpener
- » Flush Mount Switch
- » Auto Shut-Off Switch
- » Easy to Clean
- » 1/2 HP Motor 13" Blade
- » Precision Slicing Mechanism

CES Imports

7250 Santa Fe Dr.
Hodgkins, Illinois, 60525
Tel: (773) 533-3333

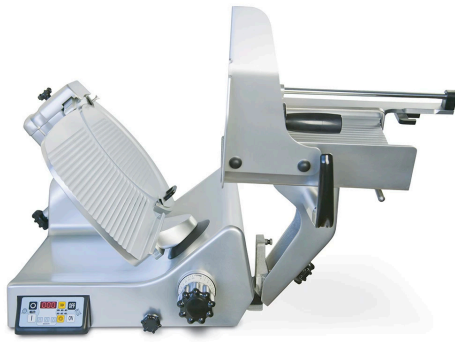

Technical Features

Overall dimensions	759 x 622 x 932 mm (31.2 x 24.5 x 36.7 inches)
Blade diameter	330 mm (13 inches)
Blade speed	255 RPM
Slice thickness	0 to 24 mm (0 to 0.94 inches)
Electrical protection	IPX3 (Motor IPX5)
Net weight	56 kg (124 lbs)
Electrical specifications	120 V 60 Hz. Single phase
Motor	1/2 HP
Carriage stroke in manual mode	345 mm (13.58 inches)
Cutting capacity long stroke	Ø 240 mm - 290 mm x 211 mm (Ø 9.45" - 11.4" x 8.3")
Cutting capacity medium stroke	Ø 201 mm - 201 mm x 201 mm (Ø 7.9" - 7.9" x 7.9")
Cutting capacity short stroke	Ø 110 mm - 110 mm x 110 mm (Ø 4.3" - 4.3" x 4.3")

Options



Lifting Device



Teflon Coated Blade



Profiled Blade

Standard equipment

- » 13" (330mm) Gravity Feed Semi-Automatic Slicer
- » 2 speeds with 3 strokes
- » Durable long lasting anodized aluminum finish
- » Precision slicing mechanism minimizing waste
- » Integrated knife Sharpener
- » Blade with enhanced cutting sections
- » Integral motor overload protection
- » Easy to load (low loading height); reduces operator strain.
- » Operator safety & cleaner working area
- » Removable sharpener, blade guard, product deflector, and remnant holder, for easy cleaning
- » Carriage with spiked and swinging remnant holder
- » Reduced foot counter space deflector for easy cleaning
- » Perfect slip grooves for a more performing sliding movement
- » Adjustable food fence
- » Self-locking clamping device
- » NSF 8 & UL Certified

Dimensions

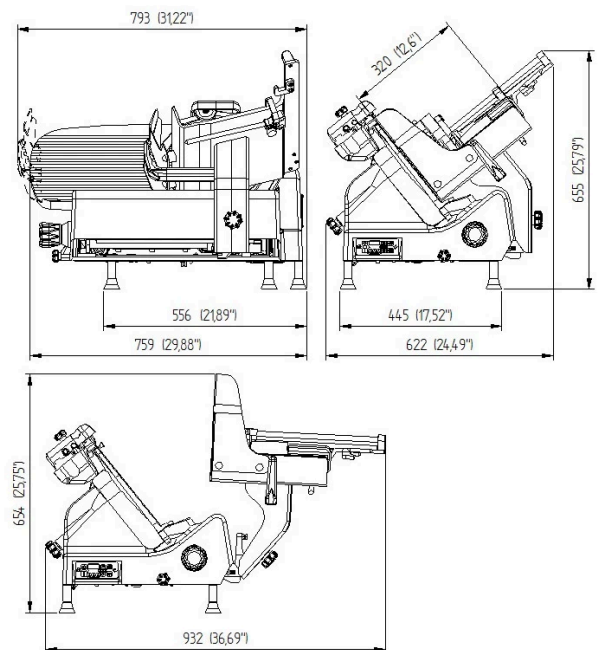

This device complies with CE safety and hygiene regulations

All information believed to be correct at the time of publishing

Ver. 1.01 20220101