

# CES *Imports*

USA Master Distributor for  
**MANCONI**  
DESIGN SLICERS BY TRADITION



Approval Pending

## **SMARTY 250 IX**

### **CES Imports**

7250 Santa Fe Dr.  
Hodgkins, Illinois, 60525  
Tel: (773) 533-3333

Website : [www.ces-imports.com](http://www.ces-imports.com) | Email : [sales@ces-imports.com](mailto:sales@ces-imports.com)

# Standard equipment

- » Belt transmission
- » Easy to use built-in sharpener
- » Great slicing accuracy
- » Low loading height to reduce the operator strain
- » Carriage with swinging sharpener pusher
- » Removable sharpener, blade cover, and meat deflector for easy cleaning
- » Perfect slip grooves for a more performing sliding movement
- » Reduced foot counter space
- » Tilting away carriage
- » Also available with black knobs and sharpener cover

# Technical Features

Overall dimensions	530 x 445 x 430 mm (20.8 x 17.5 x 16.9 inches)
Installation area	443 x 342 mm (17.4 x 13.5 inches)
Blade diameter	250 mm (9.8 inches)
Blade speed	286 g/min (1012 RPM)
Slice thickness	0 to 16 mm (0 to 0.6 inches)
Carriage travel	245 mm (9.6 inches)
Electrical protection	IPX3
Net weight	20 kg (44 lbs)
Electrical specifications	120 V 60 Hz. Single phase
Cutting capacity	Ø 180 mm - 215 x 165 mm (Ø 7.1 inches - 8.5 x 6.5 inches)

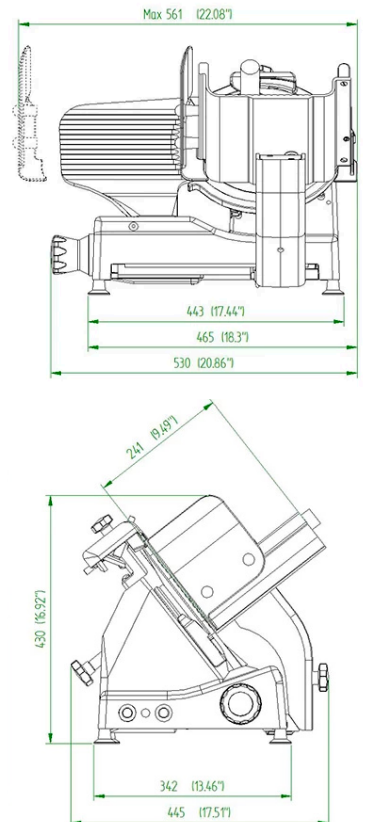

**Smarty 250 IX (Black)**



**Smarty 250 IX (Red)**



This device complies with CE safety and hygiene regulations

**All information believed to be correct at the time of publishing**

Ver. 1.01 20220101